

PE WADI-TEC ECEA GSE avec griffe d'amarage

CABLE GLAND WADI-TEC ECEA GSE
with clamping device



Métrique

Filetage Threads	Capacité Clamping range	H1 mm	H2 mm	E mm	L mm	Référence Reference	Colisage Packing
M 12	3,0 - 6,0	14	14	7,0	27	R0321200	50
M 16	3,0 - 6,0	14	17	7,0	27	R0321640	50
M 16	5,0 - 8,0	17	17	7,0	27	R0321600	50
M 20	6,0 - 10,0	20	22	7,0	28	R0322040	50
M 20	8,0 - 12,0	22	22	7,0	29	R0322000	50
M 25	9,3 - 14,0	24	26	8,0	31	R0322540	20
M 25	11,5 - 18,0	30	30	8,0	37	R0322500	20
M 32	11,5 - 18,0	30	33	8,5	38	R0323240	20
M 32	15,0 - 24,0	40	40	8,5	45	R0323200	20
M 40	15,0 - 24,0	40	42	8,5	45	R0324040	20
M 50	23,0 - 30,0	50	55	9,5	51	R0325040	10
M 63	26,0 - 35,0	58	70	10,5	58	R0326340	5

Matière :

- Laiton
- Garniture : Téfabloc
- Revêtement nickelé

Caractéristique :

- Filetage : EN 60423
- GUIDE UTE 68 312

Propriétés spécifiques :

- Presse-étoupe avec décharge de traction et joint torique

Application :

- Machines et accessoires

Material :

- Brass
- Packing ring : Tefabloc
- Nickel plated

Characteristics :

- Threads : EN 60423
- GUIDE UTE 68 312

Features :

- Cable gland with stain relief and mounted O-Ring

Application :

- Machines and devices

IP 68



Griffe ECEA pour une meilleure résistance à la traction.
ECEA clamping device for better traction resistance.

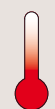

+ 100°C

- 25°C

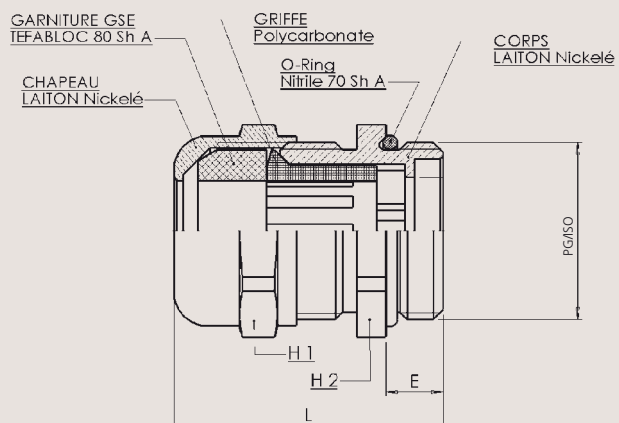

PG

Filetage Threads	Capacité Clamping range	H mm	E mm	L mm	Référence Reference	Colisage Packing
PG 07	3,0 - 6,0	14	5,0	24	R0300700	50
PG 09	5,0 - 8,0	17	6,0	25	R0300900	50
PG 11	6,0 - 10,0	20	6,0	26	R0301100	50
PG 13	8,0 - 12,0	22	6,5	28	R0301300	50
PG 16	9,5 - 14,0	24	6,5	30	R0301600	50
PG 21	11,5 - 18,0	30	7,0	35	R0302100	20
PG 29	15,0 - 24,0	40	8,0	43	R0302900	20
PG 36	23,0 - 30,0	50	9,0	50	R0303600	10
PG 42	26,0 - 35,0	58	10,0	57	R0304200	5
PG 48	35,0 - 40,0	64	10,0	59	R0304800	5
PG 48 DIN	35,0 - 40,0	64	10,0	59	R0304900	5

* Écrou voir page 54 / Locknut page from 54

* PE filetage long nous consulter / Long thread available on request

* Aussi disponible en inox nous consulter / Also available in stainless steel on request